

UVS-KO-P PLASTİK KANATLI AKSİYEL FAN UVS-KO-P PLASTIC IMPELLER AXIAL FAN



ÖZELLİKLERİ / SPECIFICATIONS

- Debi / Airflow : 1.300 - 65.000 m³/h
- Basınç / Pressure : 5 - 40 mmss
- Direkt akuple veya kayış kasnaklı / Direct coupling and belt-driven engine
- Plastik kanatlı olarak imal edilmiştir / Made of plastic plate

KULLANIM ALANLARI / AREAS OF USAGE

- Havalandırma / Aspiration
- Duman, egzost gazı ve toz tahliyesi / Aspiration of exhaust gas, dust and smoke
- Soğutma kulelerinde, asitli ortamlarda / In acitic places and cooling towers

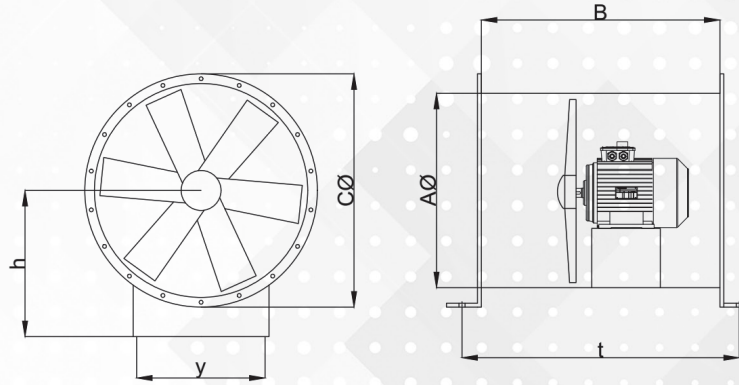

MODEL	POWER (kw)	RPM	AIRFLOW (m ³ /h)	ØA	ØC	B	t	y	h
UVS-KO-P-35	0.25	1400	3500	355	435	400	304	444	266
UVS-KO-P-40	0.37	1400	4000	400	480	450	304	494	306
UVS-KO-P-45	0.55	1400	5500	450	530	450	304	544	346
UVS-KO-P-50	0.55	1400	7000	500	600	550	304	544	396
UVS-KO-P-56	0.75	1400	9000	560	660	550	294	634	446
UVS-KO-P-63	1.1	1400	14000	630	730	600	294	634	496
UVS-KO-P-71	1.5	1400	20000	710	810	650	294	634	546
UVS-KO-P-80	2.2	1400	26000	800	900	700	384	634	616
UVS-KO-P-90	4	1400	40000	900	1000	800	384	734	686
UVS-KO-P-100	7.5	1400	56000	1000	1100	850	384	834	746

All dimensions are in mm.